

DISC PELLETIZER

FEECO International disc pelletizers are the equipment of choice when uniform pellet size and ease of size control are important in agglomerating a material.

Pellet sizing, based on disc angle, disc speed, and locations of solid and liquid feed, is easily controlled through the operational flexibility of FEECO disc pelletizers.

A simple plow/scrapper mechanism, combined with heavy duty construction methods, materials, and techniques, translates into high reliability and throughput rates.

Disc pelletizers can agglomerate fine, dry feed materials such as chemical powders, limestone, fertilizer, coal fines, cement/lime kiln dust and flyash. Disc pelletizers are also effective with wetter materials such as filter/centrifuge cake, minerals, ores, vibrating sludges and pond tailings.



Paddle mixers and pin mixers are often used as a primary feed conditioners and for binder pre-mixing. Final post treatment of pellets can be accomplished with rotary, vibrating, fluid bed, or conveyor dryers.

Laboratory and pilot scale tests will determine optimum flow schemes, equipment sizing and scaleup. If lab tests reveal that alternative agglomeration methods such as briquetting or extruding is the method of choice, FEECO can accommodate those processes as well.

If agglomeration with a disc pelletizer is the method of choice, further savings can be realized with lower investment, power consumption, and maintenance costs.

Whatever your capacity or final product specification, FEECO disc pelletizers are custom built to your specifications...to meet your operational needs.



“...the process of particle size enlargement in which small, fine particles are gathered into larger masses, clusters, pellets, or granules to achieve specified hardness for use as end products or in secondary processing steps...”

Which Materials Can Be Pelletized?

A representative list of materials which are pelletized, by industry:

Ag Chemicals: fertilizers, pesticides, herbicides, insecticides, soil conditioners, aglime, dolomite, minerals.

Cement/Lime: raw meal, kiln dust.

Ceramics: alumina, catalyst, tile mix, press feed, frits, color.

Chemicals: soda ash, sodium sulfate, detergents, cleaners, zinc oxide, pigments, dyes, pharmaceutical compounds, industrial carbons, carbon black.

Copper: concentrates, smelter dust, precipitates.

Ferrolloy: silicon, ferrosilicon, ferromanganese, ferrochrome.

Glass: glass raw mix, glass powder.

Nonmetallic minerals: clay, talc, fluorspar, diatomaceous earth.

Steel: electric furnace baghouse dust, coke fines, raw materials, iron ore pellets.

Utilities: FGD Sludge, coal dust, ash.



Pelletizing: Tumbling and Growth

Agglomeration of fine particles without pressure, by growth and tumbling in the presence of a liquid or binder, or both is usually called pelletizing. Pelletizing—the forming of spherical or spheroidal pellets—occurs in a rotating disc. Pelletizing principles involve the following sequential steps:

1. Fine raw material is continually added to the pan and wetted by a liquid binder spray.
2. The disc's rotation causes the wetted fines to form small, seed-type particles (nucleation).
3. The seed particles “snowball” by coalescence into

larger particles until they discharge from the pan.

While pellets can be formed in batches, almost all tonnage pelletizing is accomplished through continuous processes using a comparatively simply-designed disc pelletizer.

HEAVY DUTY FEECO DISC PELLETIZERS

FEECO Agglomeration: A Family of Solutions

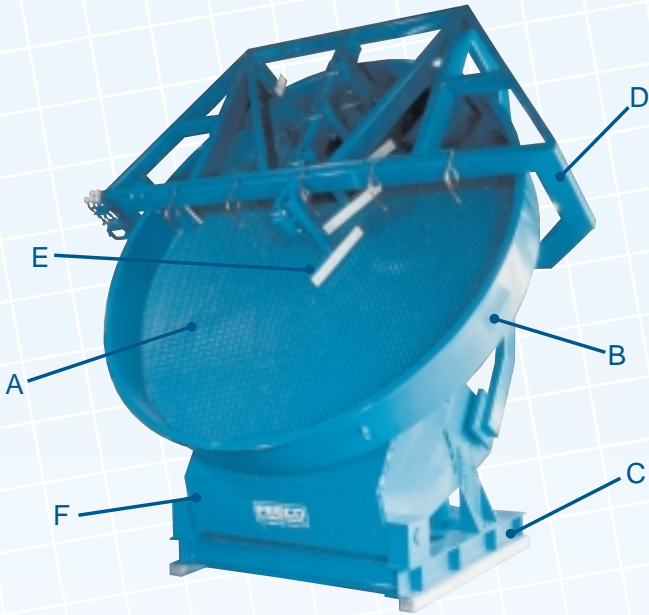

Rugged Construction

Constructed of heavy, welded, reinforced carbon steel plate (A) all inner disc bottoms six feet and larger are lined with expanded metal to reduce abrasive wear. (B) The disc angle is easily adjusted from 40° to 60° horizontal by a hand-wheel operated jacking screw (C) The base, and (D) the plow support members provide maximum rigidity while simultaneously allowing rapid pan angle adjustment, without the need for separate plow adjustment. (E) Individually mounted vane type plows easily control and maintain the product layer over the disc's entire surface. Larger pelletizers feature ceramic facings. (F) The pivot base, a rotating member, is mounted on heavy-duty anti-friction bearings.

Automatic lubrication is featured on larger discs. Precision cut, heat-treated matched spur gear sets are featured on pelletizers over 20' in diameter. All discs 20' and less are directly mounted on the output shaft of a specially designed parallel shaft reducer.

Flow Diagram for a Typical Pelletizing System

1. Raw Feed
2. Paddle/Pin Mixer
3. Binder Feed
4. Disc Pelletizer
5. Liquid Spray System
6. Transfer Conveyor
7. Rotary Dryer
8. Vibrating Screen
9. Oversize Mill
10. Recycle
11. Surge Hopper

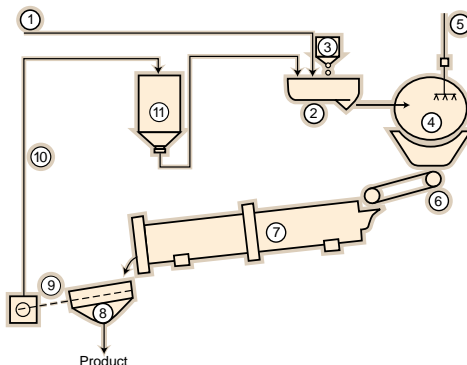

Since 1951, FEECO has been designing, manufacturing, marketing, and installing agglomeration equipment and systems, while also providing ancillary equipment to create highly efficient agglomeration processes and systems for customers throughout the world.

FEECO's field sales

representatives are among the world's most knowledgeable and experienced professionals. And they are backed by the finest chemical, mechanical, structural, and electrical engineers at FEECO's Green Bay, Wisconsin headquarters. Our sales team shares its extensive expertise and experience with customers

through seminars, professional associations, and published papers.

This knowledge and expertise is combined with modern prod-

Pelletizer Testing and Rental

FEECO International offers laboratory test facilities to determine pelletizing characteristics of various materials. Rental units are also available to allow customers hands-on testing.

Recognizing that a pelletizing disc may not be the only answer to your needs, FEECO International also designs, manufactures and installs rotary granulators, paddle mixers and pin mixers.

uction methods and a highly-skilled workforce—on-site in Green Bay—to produce highly reliable, technologically advanced agglomeration machinery and systems.

From the beginning concept of how to solve your agglomeration problem right through to the production of your machinery, FEECO International's technology-driven organization uses its full range of expertise to meet your unique agglomeration needs.

